

UNITED STATES PATENT AND TRADEMARK OFFICE

---

BEFORE THE PATENT TRIAL AND APPEAL BOARD

---

APPLE INC.,  
Petitioner,

v.

VOIP-PAL.COM, INC.,  
Patent Owner.

---

Case IPR2016-01201  
Patent 8,542,815 B2

---

Before JOSIAH C. COCKS, JENNIFER MEYER CHAGNON, and  
JOHN A. HUDALLA, *Administrative Patent Judges*.

COCKS, *Administrative Patent Judge*.

FINAL WRITTEN DECISION  
*35 U.S.C. § 318(a) and 37 C.F.R. § 42.73*

## I. INTRODUCTION

Apple Inc. (“Petitioner”) filed a Petition for *inter partes* review of claims 1, 7, 27, 28, 34, 54, 72–74, 92, 93, and 111 of U.S. Patent No. 8,542,815 B2 (Ex. 1001, “the ’815 patent”). Paper 1 (“Pet.”). Voip-Pal.com, Inc. (“Patent Owner”) filed a Preliminary Response. Paper 5 (“Prelim. Resp.”). Based on those submissions, the Board instituted trial to determine whether the above-noted claims would have been obvious over (1) Chu ’684<sup>1</sup> and Chu ’366<sup>2</sup>, and (2) Chu ’684 and Chen<sup>3</sup>. Paper 6 (“Inst. Dec.”). Patent Owner’s Request for Rehearing (Paper 9) was denied (Paper 11).

Subsequently, Patent Owner filed a Patent Owner Response. Paper 17 (“PO Resp.”). As a part of that Patent Owner Response, Patent Owner included new evidence on which it relied in contending that the Petitioner had not met the enhanced burden of establishing by a “preponderance of the evidence” (35 U.S.C. § 316(e)) the unpatentability of any of the claims of the ’815 patent. *See* Exs. 2003–2050. Petitioner filed a Reply. Paper 34 (“Pet. Reply”). Patent Owner filed a Sur-Reply. Paper 41 (“PO Sur-Reply”).<sup>4</sup> Patent Owner also filed a Motion to Exclude. Paper 40. Petitioner filed an Opposition (Paper 44), to which Patent Owner replied

---

<sup>1</sup> U.S. Patent No. 7,486,684 B2 to Chu et al. issued Feb. 3, 2009 (Ex. 1003) (“Chu ’684”).

<sup>2</sup> U.S. Patent No. 8,036,366 B2 to Chu issued Oct. 11, 2011 (Ex. 1004) (“Chu ’366”).

<sup>3</sup> U.S. Patent Application Publication No. US 2007/0064919 A1 to Chen et al. published Mar. 22, 2007 (Ex. 1005) (“Chen”).

<sup>4</sup> The Sur-Reply was authorized by the panel. Paper 37.

(Paper 47). Oral argument was conducted on July 20, 2017. A copy of the transcript of the argument was entered into the record. Paper 52.

We have jurisdiction under 35 U.S.C. § 6. This Decision is a final written decision under 35 U.S.C. § 318(a) as to the patentability of the challenged claims. For the reasons that follow, we determine Petitioner has not shown by a preponderance of the evidence that claims 1, 7, 27, 28, 34, 54, 72–74, 92, 93, and 111 of the '815 patent are unpatentable.

#### *A. Related Matters*

The parties identify the following district court proceedings in which the '815 patent has been asserted: *Voip-Pal.com, Inc. v. Apple, Inc.*, Case No. 2-16-cv-00260 (D. Nev.); and *Voip-Pal.com, Inc. v. Verizon Wireless Services, LLC*, Case No. 2-16-cv-00271 (D. Nev.). See Pet. 58; Paper 4, 1. Petitioner also has filed a petition for *inter partes* review of claims of the '815 patent in IPR2017-01399, as well as petitions in connection with related U.S. Patent No. 9,179,005 B2 (“the '005 patent”) in IPR2016-01198 and IPR2017-01398.<sup>5</sup>

#### *B. The '815 Patent*

The '815 patent is directed to classifying a call as a public network call or a private network call and producing a routing message based on that classification. Ex. 1001, Abstract. Figure 7 of the '815 patent is shown below.

---

<sup>5</sup> Trial was instituted in IPR2016-01198 on November 21, 2016. A decision regarding institution of trial in each of IPR2017-01398 and IPR2017-01399 has not yet been made.

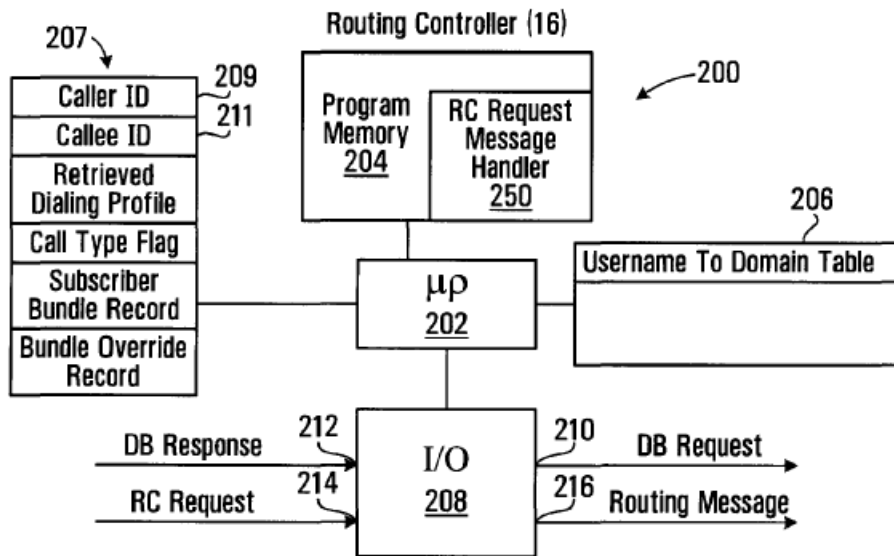

**FIG. 7**

Figure 7 above illustrates a routing controller that facilitates communication between callers and callees. *Id.* at Fig. 7, 14:24–25, 17:17–18. As shown in Figure 7, routing controller (RC) 16 includes RC processor circuit 200, which in turn includes processor 202, program memory 204, table memory 206, buffer memory 207, and I/O port 208. *Id.* at 17:17–22. Routing controller 16 queries database 18 (shown in Figure 1) to produce a routing message to connect caller and callee. *Id.* at 14:10–17, 14:24–34. Program memory 204 includes blocks of code for directing processor 202 to carry out various functions of the routing controller. *Id.* at 17:38–40. Those blocks of code include RC request message handler 250, which directs the routing controller to produce the routing message. *Id.* at 17:40–44.

In response to a calling subscriber initiating a call, the routing controller of the '815 patent:

receiv[es] a callee identifier from the calling subscriber, us[es] call classification criteria associated with the calling subscriber to classify the call as a public network call or a private network

call[,] and produc[es] a routing message identifying an address on the private network, associated with the callee[,] when the call is classified as a private network call and produc[es] a routing message identifying a gateway to the public network when the call is classified as a public network call.

*Id.* at 14:24–34.

Figures 8A through 8D of the '815 patent illustrate a flowchart of an RC request message handler executed by the RC processor circuit. *Id.* at 10:62–63. Figure 8B is reproduced below.

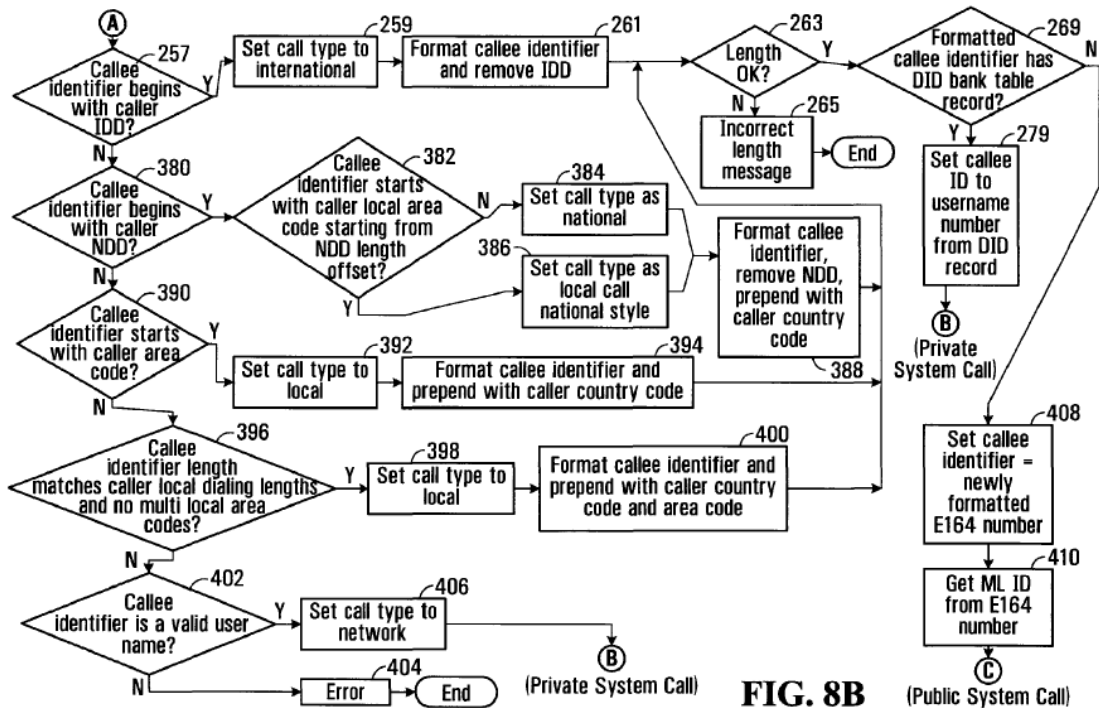

Figure 8B above illustrates steps for performing checks on the callee identifier. *Id.* at Fig. 8B, 19:45–49. Blocks 257, 380, 390, 396, 402 in Figure 8B effectively “establish call classification criteria for classifying the call as a public network call or a private network call.” *Id.* at 22:48–51. For example, block 402 “directs the processor 202 of FIG. 7 to classify the call as a private network call when the callee identifier complies with a

predefined format, i.e. is a valid user name and identifies a subscriber to the private network . . . .” *Id.* at 22:51–60. Block 269 also classifies the call as public or private, depending on whether the callee is a subscriber to the system. *Id.* at 22:51–23:8, 20:14–24; *see also id.* at 18:55–19:22.

### *C. Illustrative Claim*

Among the challenged claims, claims 1, 27, 28, 54, 74, and 93 are independent. Claim 1 is illustrative and reads:

1. A process for operating a call routing controller to facilitate communication between callers and callees in a system comprising a plurality of nodes with which callers and callees are associated, the process comprising:

in response to initiation of a call by a calling subscriber, receiving a caller identifier and a callee identifier;

locating a caller dialing profile comprising a username associated with the caller and a plurality of calling attributes associated with the caller;

determining a match when at least one of said calling attributes matches at least a portion of said callee identifier;

classifying the call as a public network call when said match meets public network classification criteria and classifying the call as a private network call when said match meets private network classification criteria;

when the call is classified as a private network call, producing a private network routing message for receipt by a call controller, said private network routing message identifying an address, on the private network, associated with the callee;

when the call is classified as a public network call, producing a public network routing message for receipt by the call controller, said public network routing message identifying a gateway to the public network.

*Id.* at 36:14–38.

## II. ANALYSIS

### A. Claim Construction

In an *inter partes* review, we construe claim terms in an unexpired patent according to their broadest reasonable construction in light of the specification of the patent in which they appear. 37 C.F.R. § 42.100(b); *Cuozzo Speed Techs., LLC v. Lee*, 136 S. Ct. 2131, 2144–46 (2016) (upholding the use of the broadest reasonable interpretation standard). Consistent with the broadest reasonable construction, claim terms are presumed to have their ordinary and customary meaning as understood by a person of ordinary skill in the art in the context of the entire patent disclosure. *In re Translogic Tech., Inc.*, 504 F.3d 1249, 1257 (Fed. Cir. 2007). An inventor may provide a meaning for a term that is different from its ordinary meaning by defining the term in the specification with reasonable clarity, deliberateness, and precision. *In re Paulsen*, 30 F.3d 1475, 1480 (Fed. Cir. 1994).

In the Institution Decision, the panel made express claim constructions for the various means-plus-function limitations appearing in the challenged claims. Inst. Dec. 7–16. Neither party has challenged those constructions, and we do not discern that any of them are in dispute. We do not revisit any of those constructions as a part of this Decision.

In addition, Patent Owner’s arguments require us to consider whether certain steps in the challenged claims must be performed in a specific order. *See* PO Resp. 50–57. More particularly, claim 1 requires “locating a caller dialing profile” that includes “a plurality of calling attributes associated with the caller,” then “determining a match when at least one of said calling attributes matches at least a portion of” a “callee identifier.” The claim goes

on to dictate that the call is classified as either a public network call or a private network call based on that match. Patent Owner contends that, because the required “calling attributes” are consulted to determine how a message is routed, this necessarily means the act of locating a caller profile that incorporates the calling attributes must have occurred prior to the step of determining a match using based on those calling attributes. *See id.*

In considering whether the steps of a claim must be performed in the order written, the first place to look is the claim language itself. *See Altris, Inc. v. Symantec Corp.*, 318 F.3d 1363, 1369–70 (Fed. Cir. 2003). In claim 1, for instance, the calling attributes of a caller dialing profile that are consulted for the purpose of determining a match, which is used to determine message routing, must necessarily have been ascertained prior to such message routing determination. Because the function of a particular component in a prior step is referenced in a subsequent step, it is the logical and natural inference that the steps are ordered with respect to one another. *See Mantech Envtl. Corp. v. Hudson Envtl. Servs., Inc.*, 152 F.3d 1368, 1375–76 (Fed. Cir. 1998) (holding that the steps of a method claim had to be performed in their written order because each subsequent step referenced something logically indicating the prior step had been performed). Petitioner does not present arguments regarding the ordering of claim steps. We conclude that, for claim 1, the pertinent steps discussed above occur in the order in which they appear in the claims. We also reach that conclusion for each of the other independent claims involved in this proceeding, all of which include a similar requirement.

We have given all other terms their ordinary and customary meaning and conclude that it is unnecessary, for purposes of this Decision, to make



any of those meanings explicit as the terms are not in dispute. *See Vivid Techs., Inc. v. Am. Sci. & Eng'g, Inc.*, 200 F.3d 795, 803 (Fed. Cir. 1999) (“[O]nly those terms need be construed that are in controversy, and only to the extent necessary to resolve the controversy.”).

*B. The Proposed Grounds of Unpatentability*

Petitioner contends that claims 1, 2, 7, 27, 28, 34, 54, 72–74, 92, 93, and 111 of the '815 patent are unpatentable under 35 U.S.C. § 103(a) as obvious over (1) Chu '684 and Chu '366, and (2) Chu '684 and Chen. Pet. 1, 6, 10–45. A claim is unpatentable under § 103(a) if the differences between the claimed subject matter and the prior art are such that the subject matter, as a whole, would have been obvious at the time the invention was made to a person having ordinary skill in the art to which said subject matter pertains. *KSR Int'l Co. v. Teleflex Inc.*, 550 U.S. 398, 406 (2007). The question of obviousness is resolved on the basis of underlying factual determinations, including: (1) the scope and content of the prior art; (2) any differences between the claimed subject matter and the prior art; (3) the level of skill in the art; and (4) where in evidence, so-called secondary considerations. *See Graham v. John Deere Co.*, 383 U.S. 1, 17–18 (1966).<sup>6</sup>

*1. Level of Skill in the Art*

In determining the level of skill in the art, various factors may be considered, including “type of problems encountered in the art; prior art solutions to those problems; rapidity with which innovations are made; sophistication of the technology; and educational level of active workers in

---

<sup>6</sup> No evidence pertaining to “secondary considerations” has been offered by either party in connection with this proceeding.

IPR2016-01201  
Patent 8,542,815 B2

the field.” *In re GPAC, Inc.*, 57 F.3d 1573, 1579 (Fed. Cir. 1995) (citing *Custom Accessories, Inc. v. Jeffrey-Allan Indus., Inc.*, 807 F.2d 955, 962 (Fed. Cir. 1986)). Furthermore, the prior art of record in this proceeding also is indicative of the level of ordinary skill in the art. *See Okajima v. Bourdeau*, 261 F.3d 1350, 1355 (Fed. Cir. 2001); *GPAC*, 57 F.3d at 1579; *In re Oelrich*, 579 F.2d 86, 91 (CCPA 1978).

Petitioner offers the following assessment of the level of ordinary skill in the art:

A person of ordinary skill in the art at the time of the '815 Patent would have been a person having at least a bachelor's degree in electrical engineering, or in a related field, with at least 2-4 years of industry experience in designing or developing packet-based and circuit-switched telecommunication systems. Additional industry experience or technical training may offset less formal education, while advanced degrees or additional formal education may offset lesser levels of industry experience. *See Ex. 1006, Houh Declaration*, at ¶ 19.

Pet. 11. Patent Owner's Declarant, Dr. William Mangione-Smith, responds with the following assessment:

Based on my review of the '815 Patent and the '005 Patent and my background and experience in the field of computer science, it is my opinion that one of ordinary skill in the art as of the priority date would be someone with an undergraduate degree in either Computer Science, Computer Engineering, Electrical Engineering, or a closely related discipline. Furthermore, I believe that such a person would also have 2 years of experience in system-level software development. In my opinion a greater degree of professional experience could serve to replace some degree of formal education. I also believe that some greater degree of formal education could serve to replace some degree of professional work experience.

Ex. 2016 ¶ 14.

The variation between the parties' assessments relates to the type of industry experience a skilled artisan would have had, i.e., "designing or developing packet-based and circuit-switched telecommunication systems" versus "system-level software development."

In considering the record before us, including the content of the prior art, we agree that ordinarily skilled artisans would have had some degree of experience with each of system-level software development and telecommunication systems. But, as both parties agree, particular industry experience and formal education are intertwined. We view the differences in the parties' assessments of the level of ordinary skill in the art as minor, but we agree with Petitioner that the record reflects that a skilled artisan's background would include some experience with telecommunication systems. Accordingly, in rendering this Final Written Decision, we adopt Petitioner's evaluation of the level of ordinary skill in the art.

## *2. Dr. Mangione-Smith's Qualifications*

Petitioner challenges Dr. Mangione-Smith's qualifications to opine on what a person of ordinary skill in the art would have understood from the teachings of the prior art. Petitioner asks that we disregard Dr. Mangione-Smith's testimony that has been introduced in the record (Ex. 2016) on the basis that he allegedly lacks experience with telephony systems. Pet. Reply 20.

In reviewing Dr. Mangione-Smith's credentials and testimony, we observe that the record reflects that he has considerable educational background, including the following degrees: a Bachelor of Science and Engineering, a Master of Science and Engineering, and a Doctor of Philosophy awarded from the University of Michigan in Ann Arbor,

Michigan. *See* Ex. 2016 ¶ 4; Ex. 2045 (CV of Dr. Mangione-Smith).

Dr. Mangione-Smith also testifies that his “technical background covers most aspects of computer system design, including low level circuitry, computer architecture, computer networking, graphics, application software, client-server application, Web technology, and system software (e.g., operating systems and compilers).” Ex. 2016 ¶ 3. Dr. Mangione-Smith also has relevant employment experience, including multi-year employment at Motorola (*see* Ex. 2045, 1), which he describes as follows:

While at Motorola, I was part of a team designing and manufacturing the first commercial battery-powered product capable of delivering Internet email over a wireless (i.e., radio frequency) link and one of the first personal digital assistants. I also served as the lead architect on the second-generation of this device. Part of my responsibilities at Motorola involved the specification, design, and testing of system control Application-Specific Integrated Circuits (“ASICs”). I conducted the initial research and advanced design that resulted in the Motorola M\*Core embedded microprocessor. M\*Core was designed to provide the high performance of desktop microprocessors with the low power of contemporaneous embedded processors. The M\*Core received widespread use in a number of communications products including various telephonic handsets, advanced pagers, and embedded infrastructure.

Ex. 2016 ¶ 5.

Dr. Mangione-Smith also testifies that in the course of his employment at the University of California at Los Angeles from 1995 to 2005 as a professor of Electrical Engineering, his lab developed “the Medibench software tool, which is widely used to design and evaluate multi-media embedded devices” and includes “software that is essential for modern digital telephony.” *Id.* ¶ 6.

In considering Dr. Mangione-Smith’s substantial technical and educational background, we are satisfied that Dr. Mangione-Smith is qualified to offer testimony in connection with what a person of ordinary skill in the art would have understood from the record at hand.

3. *Asserted Obviousness over Chu ’684 and Chu ’366*

a. *Summary of Chu ’684*

Chu ’684 describes its disclosed invention as “relat[ing] to the field of communications systems and more specifically to the management and control of voice-over Internet Protocol (VoIP) virtual private networks (VPNs) in an IP-based public branch exchange (PBX) environment.”

Ex. 1003, 1:9–13. Figure 2 of Chu ’684 is shown below.

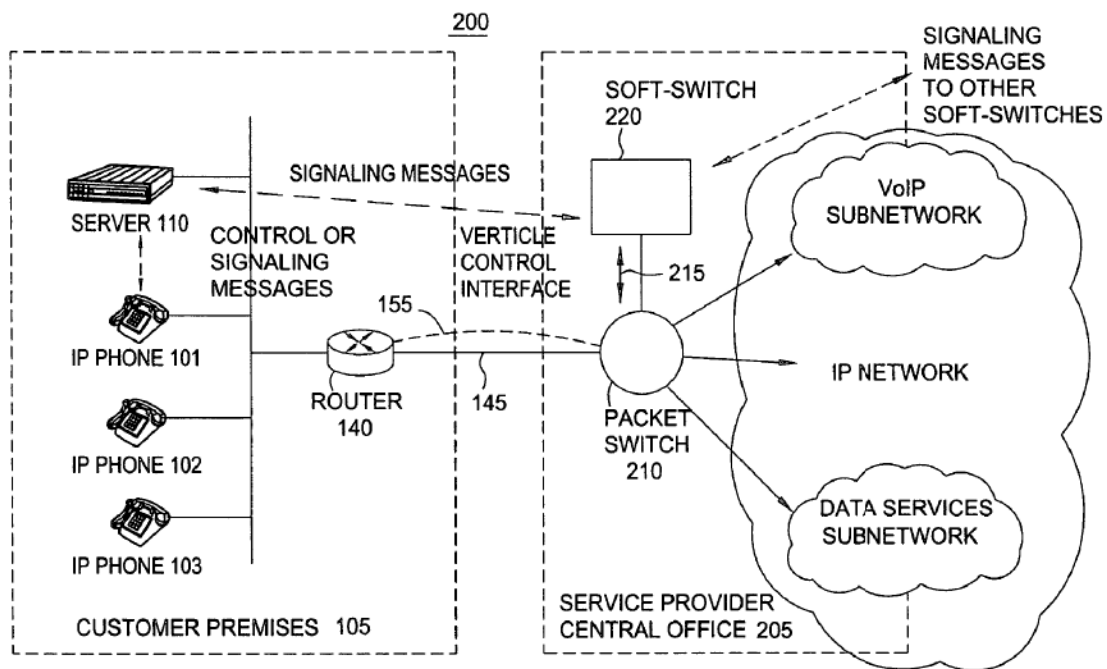

FIG. 2

Figure 2 above depicts a portion of a communications system according to an embodiment of Chu ’684’s invention. *Id.* at 3:14–15. As shown in Figure 2, communications system 200 includes customer premises 105

having IP phones 101, 102, and 103 and server 110 connected to a voice over IP (VoIP)-VPN Service Provider (SP) at SP central office 205. *Id.* at 4:24–28. Connection 145 between customer premises 105 and SP central office 205 is made via one or more routers 140. *Id.* at 4:28–30. Server 110 communicates with soft-switch 220 with an agreed-upon signaling protocol such as Session Invitation Protocol (SIP). *Id.* at 4:49–52. Soft-switch 220 sends appropriate commands to packet switch 210. *Id.* at 4:52–55. Packet switch 210 is a special media gateway that accepts voice packets from an incoming interface and switches these packets to an outgoing interface. *Id.* at 4:36–39. Soft-switch 220 “is the intelligence of the system . . . . For example, it keeps track of the VPN that a location belongs to, the dial plans of the subscribers, . . . and the like.” *Id.* at 4:59–63.

Chu ’684’s VoIP network carries both on-net (within the same VoIP VPN) and off-net (to PSTN) calls.<sup>7</sup> *Id.* at 5:17–19. Chu ’684 discloses that an “On-Net Call” sequence begins when a user picks up the handset at IP phone 101. *Id.* at 8:39–40, 8:55–56. According to Chu ’684, IP phone 101 collects dialed digits from the user and sends them to server 110. *Id.* at 8:62–64. Chu ’684 discloses that “after receiving all the dialed digits from the phone 101, server 110 consults its dial plan to determine whether the call is local, to another on-net phone, or to a phone that is on the PSTN.” *Id.* at 8:65–9:1. In this on-net example, the call is another on-net phone in another location. According to Chu ’684, server 110 sends an SIP invite message to soft-switch 220 at central office 205. *Id.* at 9:2–4. Chu ’684 discloses that soft-switch 220 “consults the dial plan for this subscriber” based on the ID

---

<sup>7</sup> “PSTN” stands for “public switched telephone network.” *Id.* at 1:34–36.

of server 110. *Id.* at 9:30–33. From the database associated with the dial plan, soft-switch 220 determines, among other things, the IP address of the egress packet switch. *Id.* at 9:34–38. Chu '684 discloses that soft-switch 220 sends an SIP invite message to the next soft-switch, the SIP message including information such as that “the call is an on-net call for a particular VPN.” *Id.* at 9:50–58.

Figure 13 of Chu '684 illustrates a configuration for establishing IP-VPN service to the PSTN. *Id.* at 13:1–3. For an outgoing call from IP phone 101, the operation is very similar to that of an intra-net call. *Id.* at 13:13–15. Chu '684 states: “From the dialed digits (of a destination phone that is being called, PSTN phone 1301), ingress soft-switch 220[] determines that this call is for the PSTN.” *Id.* at 13:15–18. From the same dialed digits, the soft-switch also determines egress PSTN gateway 1302 and its controlling soft-switch 1304. *Id.* at 13:18–20.

*b. Summary of Chu '366*

Chu '366 discloses a system for intelligent formatting of VoIP telephone numbers. Ex. 1004, Abstract. By way of background, Chu '366 explains the following:

In order to technically accommodate the growing number of telephone users around the world, and increased interest in Internet telephony, the International Telecommunications Union (ITU) has adopted a number of protocols to facilitate communications. One such protocol is E.164, which provides a uniform means for identifying any telephone number in the world to any telephony user in the world. This protocol operates for standard public switched telephone networks (PSTNs).

*Id.* at 1:18–22. Chu '366 also states that an E.164-formatted number has at most 15 digits, and contains an E.164 prefix (typically a + sign), a country

code, and a subscriber telephone number. *Id.* at 1:29–31. Chu ’366 explains that when making calls via a traditional PSTN, a subscriber is able to enter abbreviated numbers for local and national telephone calls. *Id.* at 1:35–37. For example, for a local call in the United States, a user may simply enter the seven digit telephone number without an E.164 prefix, the country code or the area code. *Id.* at 1:37–40. By contrast, Chu ’366 states, “there is no such concept of local, long distance or national calls when making a call via Internet telephony” because even for a call between two local points, that call may be routed by servers located across the globe. *Id.* at 1:44–49.

According to Chu ’366, then-existing global VoIP service providers required users to enter fully formatted E.164 telephone numbers. *Id.* at 1:49–51. Chu ’366 describes a system that allows users to enter a phone number that is not E.164-compliant, and transforms that number into one that is E.164-compliant using, for example, information from a call origin location profile. *Id.* at 1:67–2:4, 2:16–67.

*c. Discussion—Chu ’684 and Chu ’366*

Claims 1, 27, 28, 54, 74, and 93 involved in this *inter partes* review proceeding are independent. We focus, initially, on claim 1. That claim includes the following features:

in response to initiation of a call by a calling subscriber, receiving a caller identifier and a callee identifier;

locating a caller dialing profile comprising a username associated with the caller and a plurality of calling attributes associated with the caller;

determining a match when at least one of said calling attributes matches at least a portion of said callee identifier;

classifying the call as a public network call when said match meets public network classification criteria and



classifying the call as a private network call when said match meets private network classification criteria;

when the call is classified as a private network call, producing a private network routing message for receipt by a call controller, said private network routing message identifying an address, on the private network, associated with the callee;

when the call is classified as a public network call, producing a public network routing message for receipt by the call controller, said public network routing message identifying a gateway to the public network.

Thus, claim 1 requires that at least one “calling attribute” associated with a caller is evaluated to determine if that calling attribute matches a portion of a callee identifier. The call is classified as a public network call or a private network call based on whether that match meets public or private network classification criteria. Either a private network routing message is produced for receipt by the call controller identifying a private network address associated with the callee, or a public network routing address is produced which identifies a gateway to the public network.

A core basis of dispute between Petitioner and Patent Owner centers on the above-noted features of the claims. Specifically, the parties disagree as to whether the proposed combination of the teachings of the prior art, e.g., Chu '684 and Chu '366, teaches the production of a routing message for a call when each of “calling attributes” associated with the caller and a portion of a “callee identifier” meet either public or private network classification criteria. *Compare* Pet. 1 (“[T]he purportedly distinguishing feature of the '815 Patent of using attributes about a caller to determine whether a call is routed to a private or public network was present in the prior art.”), *with* PO Resp. 46 (“The cited references, individually or in combination, fail to provide any teaching or suggestion of classifying calls by network (i.e.,

private network or public network) based on whether a ‘match’ between the caller’s ‘calling attributes’ and the callee identifier meets private or public ‘network classification criteria’ in the manner recited in the challenged claims.”) The parties also disagree whether Petitioner has shown adequate reasoning to combine the teachings of Chu ’684 and Chu ’366. We address these disagreements between the parties below.

*i. Proposed reasoning to combine*

Petitioner offers the following reasons why a skilled artisan would have modified Chu ’684 based on Chu ’366’s disclosure:

It would have been obvious to one of skill in the art to modify the system described by *Chu ’684* with the specific dialed digit reformatting teachings of *Chu ’366*. Given that the system of *Chu ’684* already contains all the infrastructure needed to support such reformatting, the modification to *Chu ’684* would be straightforward, not requiring undue experimentation, and would produce predictable results. Upon reading the disclosure of *Chu ’684*, a person of ordinary skill in the art would have recognized that allowing users to place calls as if they were dialing from a standard PSTN phone would be desirable, creating a system capable of supporting a more intuitive and user-friendly interface. *See Ex. 1006, Houh Decl.* at ¶¶ 35-39.

One of ordinary skill would thus have appreciated that these improvements to *Chu ’684* could be achieved by merely programming the system of *Chu ’684* to analyze the dialed digits and reformat as necessary using caller attributes such as national and area code. Such modifications are simply a combination of the system of *Chu ’684* with elements of *Chu ’366* that would have yielded predictable results without requiring undue experimentation. *See Ex. 1006, Houh Decl.* at ¶ 38. Thus, it would have been natural and an application of nothing more than ordinary skill and common sense to combine *Chu ’684* with the number reformatting of *Chu ’366*. *Id.*

Pet. 19.

The underlying premise of Petitioner’s proposal to combine the teachings of Chu ’366 with those of Chu ’684 is that a skilled artisan would have viewed Chu ’684’s interface as less “intuitive” and less “user-friendly” than that of Chu ’366, thus giving rise to a desire to improve Chu ’684’s system. *Id.* As support for that proposal, Petitioner relies on the testimony of Dr. Houh spanning paragraphs 35 to 39 of his Declaration. In those paragraphs, Dr. Houh essentially expresses the same statements as those reproduced above. Notably absent, however, from both the Petition and Dr. Houh’s testimony is underlying evidentiary support for the proposition that one of ordinary skill in the art would have regarded Chu ’684’s teachings as deficient. Indeed, Petitioner’s statement and Dr. Houh’s bare testimony that “[u]pon reading the disclosure of Chu ’684,” a person of ordinary skill in the art would have sought to improve that very disclosure seemingly warrants underlying explanation or citation, yet no adequate support in that regard is supplied. *See* Pet. 19; Ex. 1006 ¶ 38.

Moreover, this panel has the benefit of Dr. Mangione-Smith’s testimony, in which he expresses disagreement with the positions noted above taken by Dr. Houh and Petitioner and highlights the potential inadequacies in that respect. *See* Ex. 2016 ¶¶ 65–67. Indeed, we credit Dr. Mangione-Smith’s view that Dr. Houh does not explain adequately the nature of the deficiency in Chu ’684 that is intended to be addressed. *Id.* ¶ 66. We also observe that Chu ’684 characterizes its disclosed invention as being “innovative,” “novel,” and overcoming “disadvantages” associated with the prior art. Ex. 1003, 2:28–29, 2:33–35. That Chu ’684 praises its own disclosure is unsurprising. Petitioner’s contention, however, that

Chu '684 itself would have suggested a deficiency and a need for improvement is incongruent with the content of this reference.

Both Petitioner and Dr. Houh offer “common sense” as an additional rationale underlying the combination of Chu '684 and Chu '366. Pet. 19; Ex. 1006 ¶ 38. Recourse to “common sense” certainly has its place in considering the question of obviousness. *See KSR*, 550 U.S. at 421 (“When there is a design need or market pressure to solve a problem and there are a finite number of identified, predictable solutions, a person of ordinary skill has good reason to pursue the known options within his or her technical grasp. If this leads to the anticipated success, it is likely the product not of innovation but of ordinary skill and common sense.”). Yet, here, the reliance on a theory of “common sense” is unexplained. As our reviewing court has observed, “[a]bsent some articulated rationale, a finding that a combination of prior art would have been ‘common sense’ or ‘intuitive’ is no different than merely stating that the combination ‘would have been obvious.’” *In re Van Os*, 844 F.3d 1359, 1361 (Fed. Cir. 2017). On this record, we do not agree that a skilled artisan would have regarded Chu '684 as deficient and ripe for improvement. Accordingly, we determine that Petitioner has not articulated persuasive reasoning with a rational underpinning for combining the teachings of Chu '684 and Chu '366.

We have considered the Petition and its underlying supporting evidence. We also have considered the record that has developed during the course of the trial, which includes the Patent Owner Response and all its underlying supporting evidence. The burden to show unpatentability remains on a petitioner throughout the course of an *inter partes* review proceeding. *See Dynamic Drinkware, LLC v. Nat'l Graphics, Inc.*, 800 F.3d

1375, 1378–79 (Fed. Cir. 2015) (citing *Tech. Licensing Corp. v. Videotek, Inc.*, 545 F.3d 1316, 1326–27 (Fed. Cir. 2008)) (discussing the burdens of persuasion and production in *inter partes* review). In that respect, in connection with a final written decision, that burden of establishing unpatentability is by a preponderance of the evidence. *See* 35 U.S.C. § 316(e); 37 C.F.R. § 42.1(d). In satisfying that burden, and as a part of an obviousness showing, a petitioner must establish articulated reasoning with some rational underpinning. *See In re Kahn*, 441 F.3d 977, 988 (Fed. Cir. 2006) (“[R]ejections on obviousness grounds cannot be sustained by mere conclusory statements; instead, there must be some articulated reasoning with some rational underpinning to support the legal conclusion of obviousness.”). After careful review of the record at hand, we find Petitioner’s reasons for combining the teachings of Chu ’684 and Chu ’366 to be conclusory and insufficient to carry the burden of demonstrating unpatentability by a preponderance of the evidence.

*ii. The claim requirement of using “calling attributes” associated with a caller for producing routing messages*

Even if, *arguendo*, we were to accept Petitioner’s premise that a person of ordinary skill in the art would have recognized a deficiency in Chu ’684, and that Chu ’366’s teachings resolve that deficiency, we consider carefully the nature of Petitioner’s reliance on Chu ’366. Petitioner turns to Chu ’366 to account for the requirement that, in conjunction with a least a portion of a callee identifier being the basis for routing messages, it is a calling attribute associated with a caller that is also employed. *See* Pet. 18–22 (“Chu ’366 teaches reformatting dialed digits to generate an E.164 compliant callee identifier when dialed digits ‘match’ caller attributes, e.g.,

when the dialed digits equal the national dialing length of the caller's origin designation.”).

According to Petitioner, “[o]nce the callee identifier is reformatted, Chu ’684 determines whether the callee is a private packet network subscriber or a public PSTN customer (i.e., whether the call ‘meets public network classification criteria’ or ‘private network classification criteria.’).” *Id.* at 23. Thus, Petitioner seems to advocate that Chu ’684, itself, contemplates a “reformatted” callee identifier when determining the public or private network affiliation of a call. The basis for that contention rests on the following sentence in Chu ’684: “[a]t step 608, after receiving all the dialed digits from the phone 101, server 110 consults its dial plan to determine whether the call is local, to another on-net phone, or to a phone that is on the PSTN.” *Id.* at 18 (citing Ex. 1003, 8:65–9:1).

It is not apparent to us that Chu ’684 discloses any reformatting of a callee identifier (i.e., dialed digits). Indeed, the “reformatting” of dialed digits is the distinct basis for Petitioner’s reliance on Chu ’366. Yet Chu ’684 discloses that the “dialed digits” themselves are the basis of determining “whether the call is local, to another on-net phone, or to a phone that is one the PSTN.” Ex. 1003, 8:65–9:1. Dr. Mangione-Smith’s testimony confirms this; he testifies that Petitioner’s characterization of Chu ’684 “is wrong – the cited passage in Chu ’684 at 8:65–9:1 (describing ‘step 608’) does indicate that the dial plan is consulted based [on] using knowledge of the enterprise – but the analysis of the dialed digits does not require knowledge of the attributes of a caller.” Ex. 2016 ¶ 71. In that respect, we credit Dr. Mangione-Smith’s testimony and conclude that the system of Chu ’684 analyzes or evaluates the unaltered “dialed digits” to

determine the local or non-local (i.e., PSTN) nature of a call. Petitioner's proposition that Chu '684's teachings would, nevertheless, apply to a reformatted number is at odds with Chu '684's disclosure. Put differently, if Chu '684's dialed digits are reformatted prior to determining the local or non-local (i.e., PSTN) nature of a call, then it stands to reason that they no longer constitute the dialed digits. Petitioner has not explained adequately why or how Chu '684's step of assessing the dialed digits is applicable to a reformatted number that is no longer the dialed digits.

Furthermore, Petitioner contends that the claims are rendered obvious "by merely programming the system of *Chu '684* to analyze the dialed digits and reformat *as necessary* using caller attributes such as national and area code." Pet. 19 (second emphasis added). Left wanting from that contention is adequate support in the record as to why or how one of ordinary skill would evaluate when it is "necessary" to reprogram Chu '684's system. Petitioner's position in that regard is not grounded in what a skilled artisan would have gleaned from the teachings of the prior art, and is instead an impermissible exercise of hindsight with the claims of the '815 patent serving as a guide. Such a position is not appropriate for a conclusion of obviousness. *See Otsuka Pharm. Co., Ltd. v. Sandoz, Inc.*, 678 F.3d 1280, 1296 ("The inventor's own path itself never leads to a conclusion of obviousness; that is hindsight.").

Further still, as discussed above, we construe all the challenged claims of the '815 patent as requiring an act of locating a caller dialing profile comprising a plurality of calling attributes associated with a caller, determining at match of the calling attributes and a portion of the callee identifier, and then classifying the call based on the match in producing a

routing message. Correspondingly, Patent Owner contends Petitioner has not accounted properly for the step ordering required by the claims in its grounds of unpatentability. *See* PO Resp. 50–57. In conjunction with the step in claim 1 of locating a caller dialing profile comprising a plurality of calling attributes associated with a caller, Petitioner points to Chu '684's disclosure at column 9, lines 30–33. Pet. 21–22. This portion of Chu '684 concerns its disclosed “step 610” and reads: “[a]t step 610, upon receipt of the SIP ‘invite’ message from the server 110, the soft-switch 220 consults the dial plan for this subscriber. The dial plan to use can be determined from the ID of the server 110.” Ex. 1003, 9:30–33.

Petitioner subsequently relies on Chu '684's disclosure at column 8, line 65 through column 9, line 1, pertaining to Chu '684's “step 608” to account for the act of “determining a match” and “classifying the call” based on that match to determine whether public or private network criteria have been met. Pet. 22–23. Yet, the performance of Chu '684's “step 608” occurs temporally *before* the performance of “step 610.” That Petitioner relies on Chu '684's “step 610” for “locating a caller dialing profile,” and then relies on Chu '684's *prior* “step 608” for the *subsequent* steps of “determining a match” and “classifying the call” is at odds, or is inconsistent, with the step ordering that is required by the claims of the '815 patent.

Accordingly, for all the above-noted reasons, we are not satisfied on the record before us that Petitioner has accounted adequately for the requirement that calling attributes associated with a caller form the basis, in-part, for ultimately assessing whether private network or public network classification criteria have been met and routing of messages based on that



assessment. We observe that a similar such requirement exists in each of the independent claims 1, 27, 28, 54, 74, and 93, and also each of the claims that depend therefrom.

*d. Conclusion—Chu '684 and Chu '366*

We have reviewed the record that developed during trial. As already discussed, in connection with a final written decision in an *inter partes* review, the burden of showing unpatentability by a preponderance of the evidence lies with the petitioner. We have weighed the evidence before us, both that in support of unpatentability and that in support of patentability. On balance, we conclude that Petitioner has not met its burden of showing, by a preponderance of the evidence, the unpatentability of any of claims 1, 7, 27, 28, 34, 54, 72–74, 92, 93, and 111 of the '815 patent based on Chu '684 and Chu '366.

*4. Asserted Obviousness over Chu '684 and Chen*

Petitioner contends that claims 1, 7, 27, 28, 34, 54, 72–74, 92, 93, and 111 of the '815 patent are unpatentable under 35 U.S.C. § 103(a) as obvious over Chu '684 and Chen. Pet. 5, 37–58. Relying in part on the testimony of Dr. Houh, Petitioner argues that the references allegedly teach or suggest the claim limitations and provides purported reasoning for combining the teachings of the references. *Id.* at 37–58.

*a. Summary of Chen*

Chen discloses a method for translating between different dial plans “so that a user in any region or country may place phone calls in a familiar manner.” Ex. 1005 ¶¶ 2, 15. Chen explains that E.164 defines an international public telecommunication number plan and requires a format of “+country code-area code-subscriber number.” *Id.* ¶¶ 6, 11. Chen notes that

a different numbering plan, such as a regional or countrywide numbering plan, defines the dial plan for local and long distance calls. *Id.* ¶ 12.

Figures 6 and 7 of Chen disclose algorithms for translating between E.164 and regional numbering plans. *Id.* ¶¶ 35–47. Figure 6 is shown below.

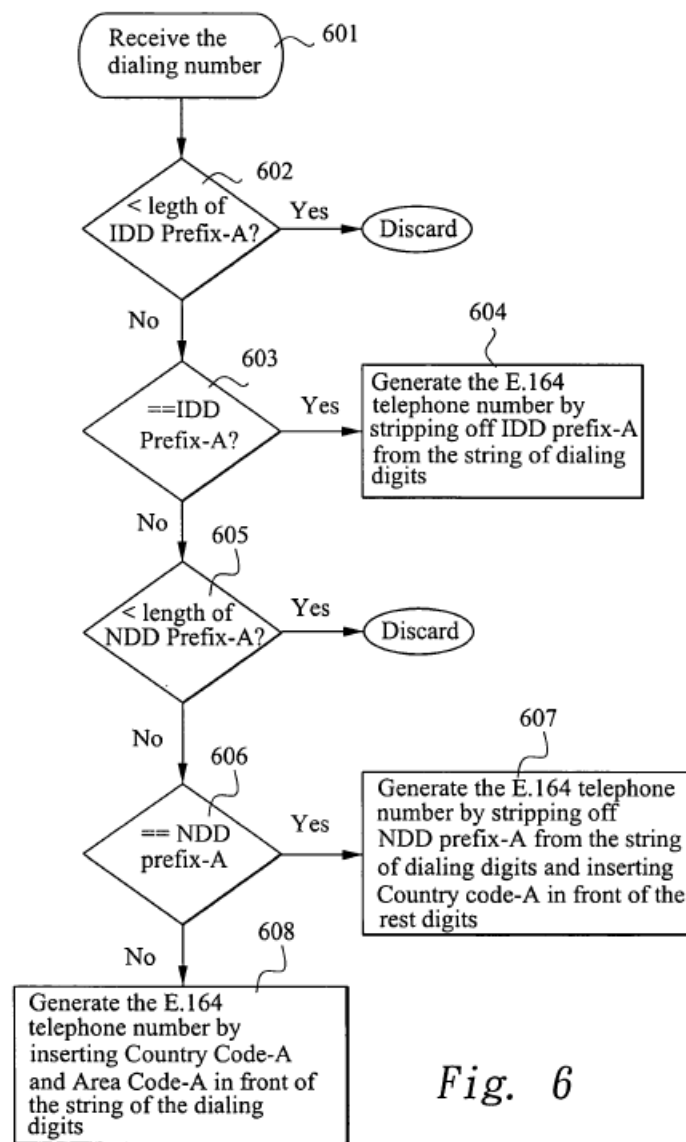

Fig. 6

As illustrated in Figure 6 above, Chen discloses determining whether a dialed number has a particular format that contains an International Dialing Digit prefix (“+”) or a National Dialing Digits prefix (e.g., “1” for North America), and generating an E.164-compliant number by inserting the

applicable country code and area code. *Id.* ¶¶ 33–40, Fig. 6. Figure 7 illustrates steps for translating an E.164-compliant number to the format of a different dial plan, such as that for a Session Initiation Protocol (SIP) phone. *Id.* ¶¶ 27, 41–48, 52, Fig. 7.

*b. Discussion—Chu ’684 and Chen*

Petitioner relies on essentially the same analysis from the Chu ’684-Chu ’366 ground to show that the subject matter of the challenged claims would have been obvious in view of Chu ’684 and Chen. *Compare* Pet. 37–58, *with id.* at 12–36. Patent Owner contends that Petitioner’s reliance on Chen has the same deficiencies as those it identifies in connection with Petitioner’s reliance on Chu ’366. *See generally* PO Resp.

Having reviewed the entirety of the record before us, we determine that Petitioner’s ground of unpatentability based on Chu ’684 and Chen has the same deficiencies discussed above in connection with the ground based on Chu ’684 and Chu ’366. Accordingly, we conclude that, on this record, Petitioner has not met its burden of showing, by a preponderance of the evidence, the unpatentability of claims 1, 7, 27, 28, 34, 54, 72–74, 92, 93, and 111 of the ’815 patent based on Chu ’684 and Chen.

*C. Patent Owner’s Motion to Exclude*

Patent Owner seeks to exclude various exhibits offered by Petitioner in support of the Petitioner Reply. Paper 40, 1–15. We observe that, by and large, the reasons advanced by Patent Owner for the exclusion of the pertinent exhibits are more germane to the weight to be afforded the exhibits rather than their admissibility. In any event, the pertinent exhibits either did not factor into this Decision, or were regarded in a way not detrimental to

Patent Owner. Accordingly, we dismiss Patent Owner's Motion to Exclude as moot.

### III. CONCLUSION

For the above reasons, we determine that the record in this proceeding does not establish, by a preponderance of the evidence, the unpatentability of claims 1, 7, 27, 28, 34, 54, 72–74, 92, 93, and 111 of the '815 patent.

### IV. ORDER

It is

ORDERED that Petitioner has not shown by a preponderance of the evidence that claims 1, 7, 27, 28, 34, 54, 72–74, 92, 93, and 111 of the '815 patent are unpatentable;

FURTHER ORDERED that Patent Owner's Motion to Exclude is *dismissed as moot*; and

FURTHER ORDERED that this is a Final Written Decision under 35 U.S.C. § 318(a), and that parties to the proceeding seeking judicial review of the decision under 35 U.S.C. § 319 must comply with the notice and service requirements of 37 C.F.R. § 90.2.

IPR2016-01201  
Patent 8,542,815 B2

FOR PETITIONER:

Adam P. Seitz  
Eric A. Buresh  
Paul R. Hart  
ERISE IP, P.A.  
adam.seitz@eriseip.com  
eric.buresh@eriseip.com  
paul.hart@eriseip.com

FOR PATENT OWNER:

Kerry Taylor  
John M. Carson  
KNOBBE, MARTENS, OLSON & BEAR, LLP  
2kst@knobbe.com  
2jmc@knobbe.com  
BoxDigifonica@knobbe.com